

PALLETISER

Taros

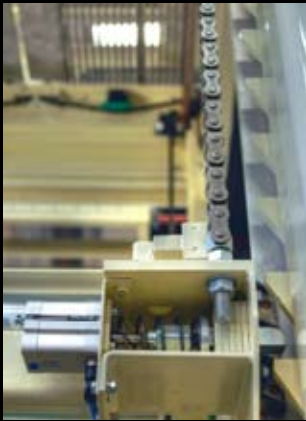

- Minimum floor space required
- Maximum flexibility
- Cost-effective

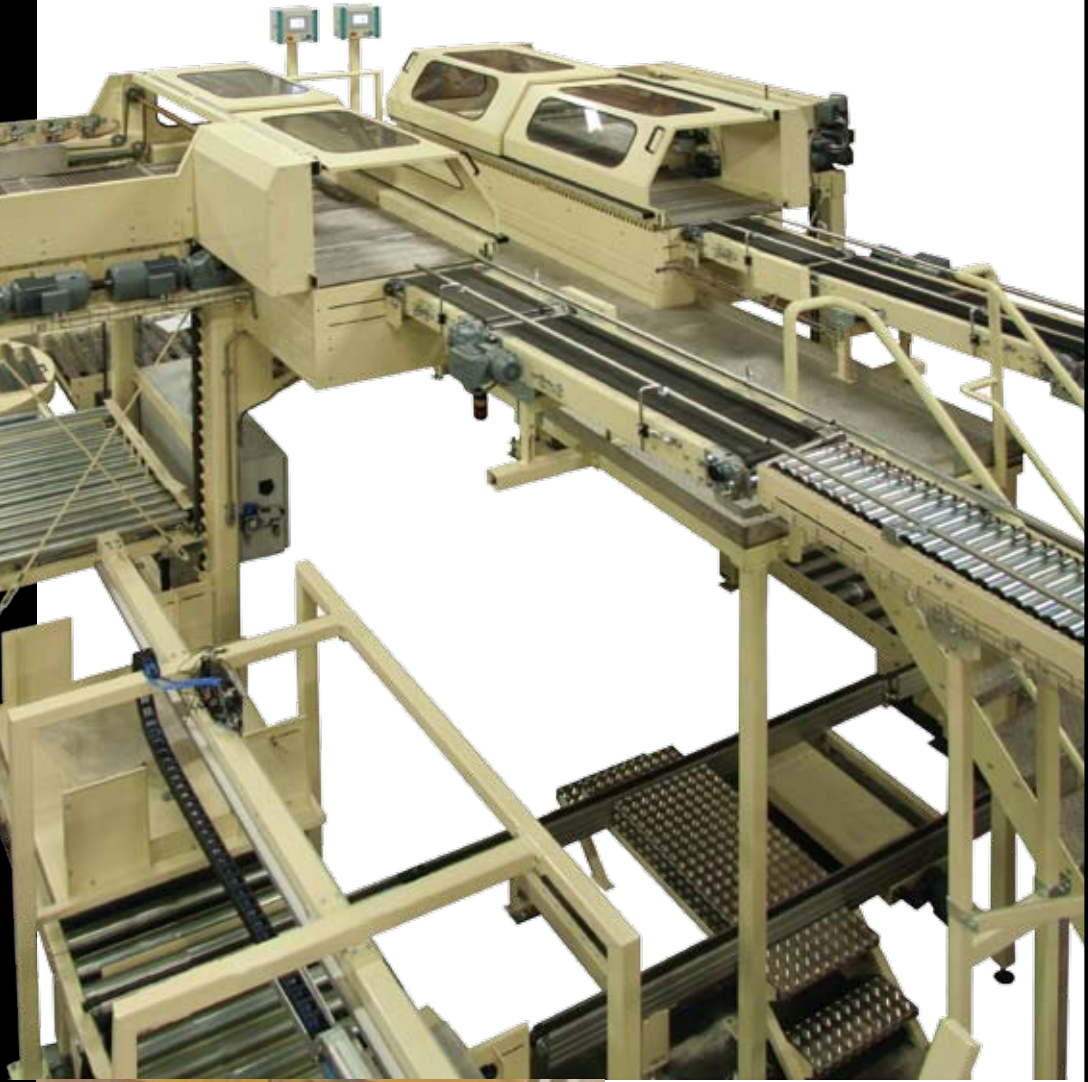

Ivanhoe is a division
of the CSI group

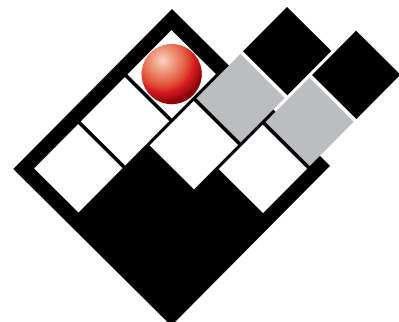

IVANHOE

www.ivanhoeweb.nl

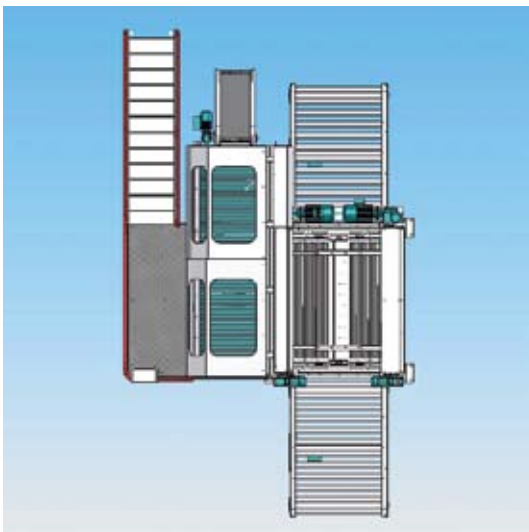
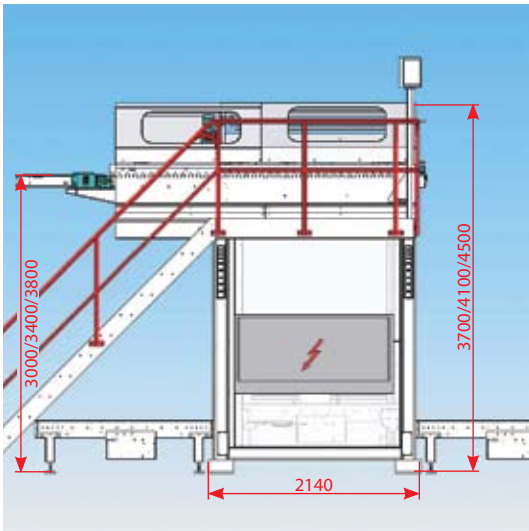
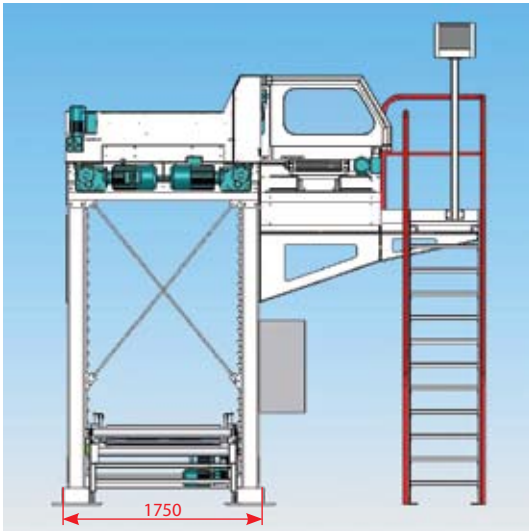

Specifications

Product types

Cartons, trays, foil packages, bundles, display packaging, etc.

Max. product dimensions

600 x 400 x 500 mm (LxWxH)

Max. load

250 kg per layer, 1500 kg per pallet

Loading height

Up to 2800 mm including pallet

Pallet specifications

Chep, Euro, 2x½ Euro, Industrial

Capacity

Up to 50 cartons/min, depending of the dimensions of the packs, packs per layer and layer pattern

Controls

Modular control system
Operator panel with touch screen

Main voltage

230/400 V, 50 Hz

Options

Row or layer accumulation station
Layer sheet dispenser
Extensive modular control system

More information

P.O. Box 70, 4940 AB Raamsdonksveer
the Netherlands
tel.: +31 (0) 162 575 000
fax: +31 (0) 162 575 119
e-mail: info@ivanhoeweb.nl
internet: www.ivanhoeweb.nl

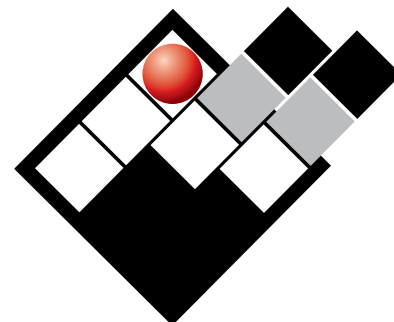

IVANHOE